

50HZ



0.3HP



0.5~1HP



2~3HP



5~7.5HP

Features

- Dry motor with overload protector; Cable with an epoxy resin sealed water-proof cable hood; Use deep groove C3 bearing to extend life time.
- Superior abrasion resistant double mechanical seal to ensure best seal effect.
- Oil seal mounted outside of seal chamber stops solids gathering around seal faces.
- Equipped with SUS304 strainer to prevent impeller from being blocked or damaged by sewage or solids.

Motor Spec.

- 2P dry type motor.
- Insulation: F class.
- Protection: IP68.
- Frequency: 50HZ.
- Voltage: 1ø220~240V(0.5~2HP).
3ø220~440V(all models).



EA Volute Impeller

Applications

- Wastewater, sump drainage from basement of buildings, hotels, schools, restaurants, malls, subway, construction site, public places..etc.
- Rainwater effluent, accumulated water drainage ,flood control, water circulation of aquaculture and landscape ponds..etc.

Optional

Submersible sump pump with guide rail device



Optional Single phase sump pump with auto float switch. (0.5~2HP)



Parts and Materials List

No.	Parts	Standard Material
		EA Model
1	Cable	STOW
2	Cable hood	PVC
3	Handle	Nylon6 or SS400
4	Motor cover	Nylon66 or FC200
5	Seal housing	FC200
6	Bracket	FC200
7	Oil chamber	FC200
8	Pump casing	FC200
9	Impeller	FC200
10	Strainer	SUS304
11	Mech. seal	CA/CE
12	Oil seal	NBR
13	Bearing	(NTN brand)
14	Overload protector	(T.I.brand)
15	Shaft	SUS410
16	Motor housing	SUS304
17	Lubricant oil	(Turbine Oil ISO VG46)

• Mech.seal (sic/sic)material is available upon request.

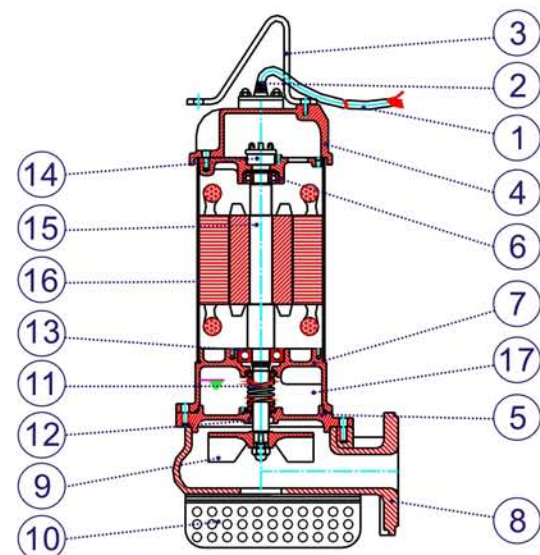

Operating Conditions

- Water temperature: 0~40°C.
- Ambient temperature: 0~40°C.
- Solid passage: 6MM.
- Operating water depth: Max.8~10M.
- No use in sea water and high-corrosive liquids.
- No 24hrs continuously running.

Model Code

EA-20(A)(T)

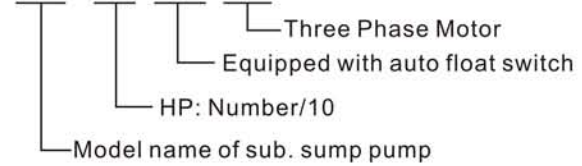

Performance Curves

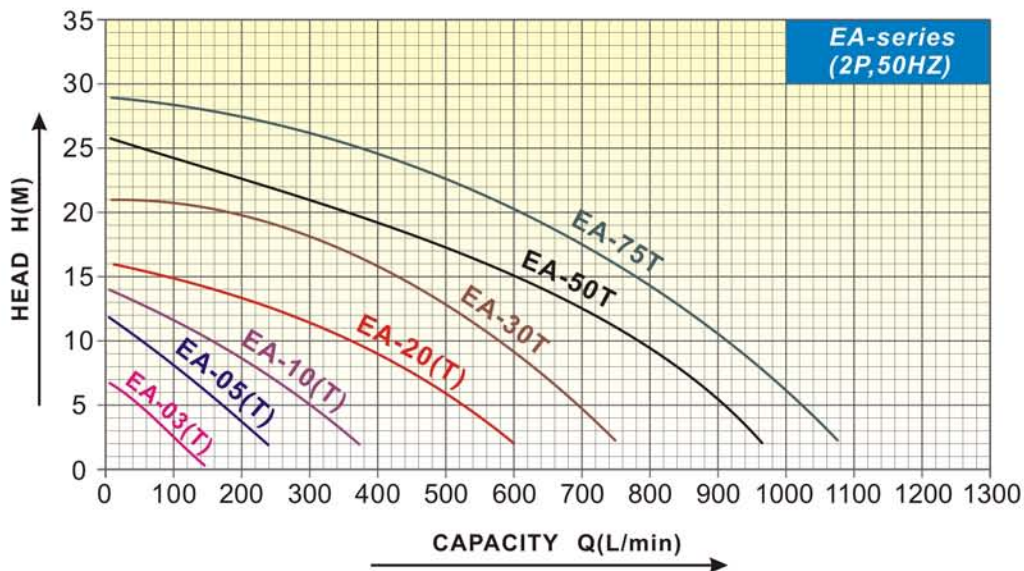

Specification & Dimensions

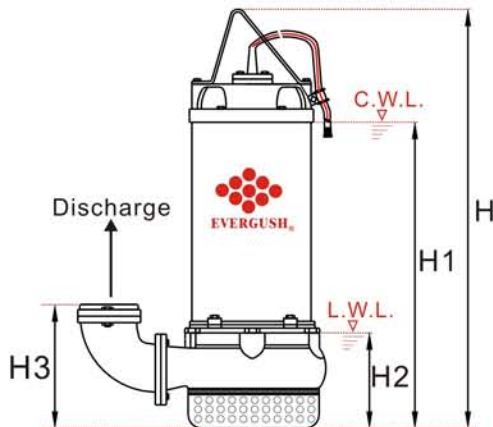

NOTE: Forbid running submersible pumps continuously under L.W.L.

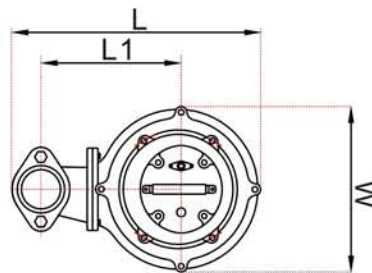

C.W.L.: Continuously Running Water Level.
L.W.L.: Lowest Running Water Level.

Model	Power		Disch. Inch	Phase φ	Rated		Max.		Dimensions (mm)						Cable M	Net Weight KG	Solid Passage MM	
	KW	HP			Head M	Capacity LPM	Head M	Cap. LPM	L	L1	W	H	H1	H2				H3
EA-03(A)(T)	0.25	0.3	1.5"	1,3	4~5	70~50	7	150	195	135	138	325	213	75	73	5	9	5
EA-05(A)(T)	0.37	0.5	2"	1,3	5~6	175~150	12	260	221	115	141	373	260	76	97	5	13	6
EA-10(A)(T)	0.75	1	2"	1,3	8~10	220~155	14	400	330	193	173	451	327	100	155	5	23	6
EA-20(A)(T)	1.5	2	2"(3")	1,3	9~10	400~360	16	650	403	250	212	536	388	110	164	5	33	8
EA-30T	2.2	3	2"(3")	1,3	11~15	550~430	21	800	403	250	212	556	408	110	164	5	35	8
EA-50T	3.7	5	3"(4")	3	12~15	720~600	26	1000	463	260	227	605	440	132	215	5	55	10
EA-75T	5.5	7.5	3"(4")	3	16~18	750~680	29	1100	463	260	227	645	480	132	215	5	61	10

Remarks: ●(A): Equipped with automatic float switch. ●(T): Three phase motor. ●10M cable are available for all models per special request.

50HZ



Product Features:

- Through simple and convenient installation, we can connect the pump onto guide rail device. Whenever the pump needs maintenance, it can be easily pulled out through guide bar to dismantle, repair or examine the pump. For safety purpose, The workers no longer need to go down the septic tank to do maintenance. It will greatly reduce down time.

Applications:

- Animal husbandry and dairying septic tank waste water drainage; sewers, apartments, buildings and basements sewage treatment equipment drainage; Dye house, fur and leather industry and steel industry waste water drainage; other waste water treatments drainage.

Installation Diagram:

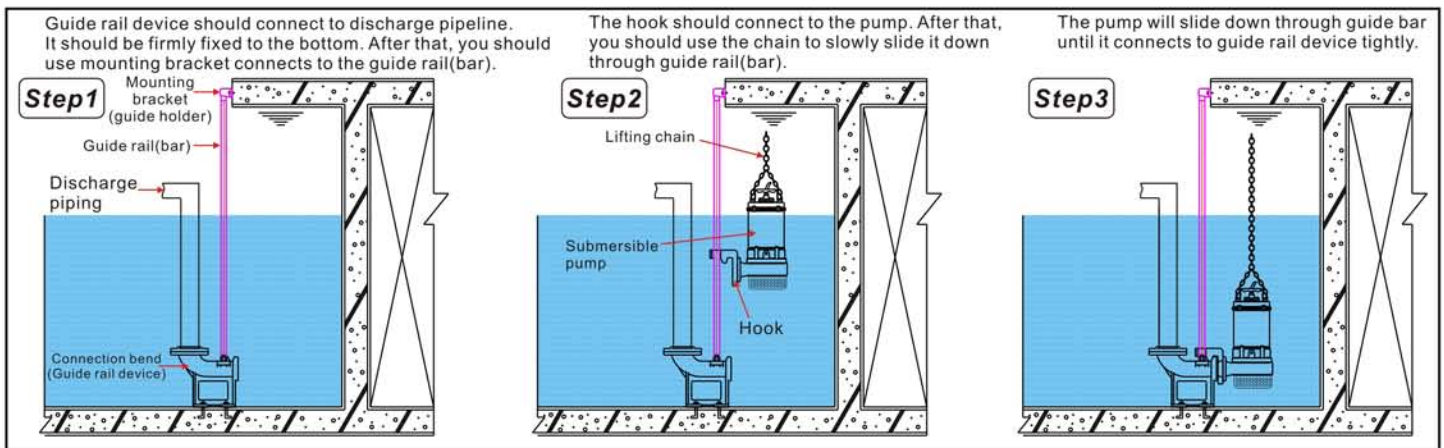

Dimensions:

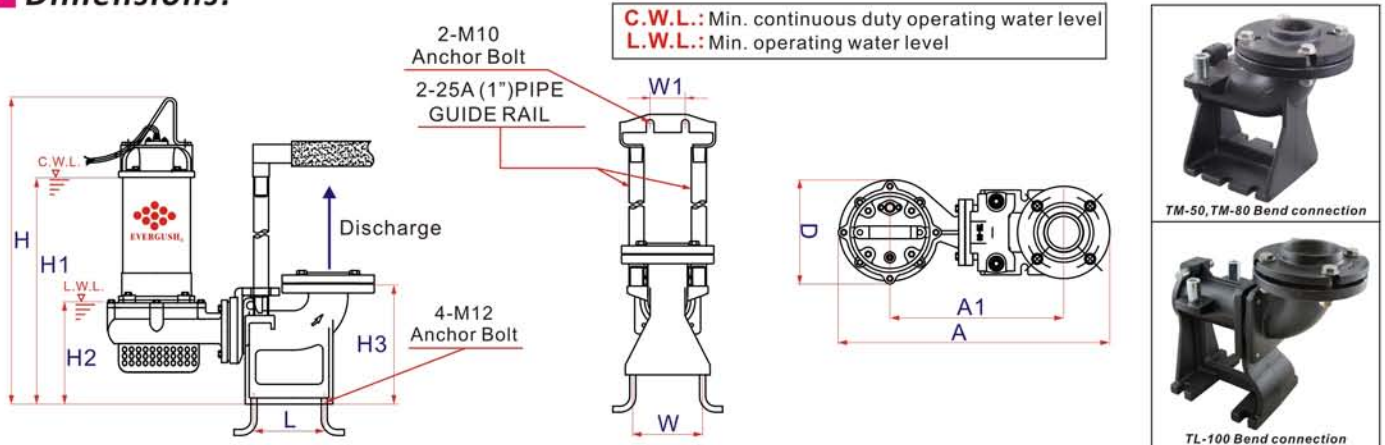

Model	Matched TOS Model	Power HP	Disch. Inch	Dimensions(mm)										Weight(KG)	
				A	A1	D	H	H1	H2	H3	L	W	W I	TOS Device	TOS & PUMP
TOS-EA-05(T)	TM-50	0.5	2"	490	311	173	469	356	172	243	110	140	70	16	29
TOS-EA-10(T)	TM-50	1	2"	490	311	173	524	400	172	243	110	140	70	16	34
TOS-EA-20(T)	TM-80	2	3"	564	368	210	601	453	175	243	110	140	70	16	50
TOS-EA-30T	TM-80	3	3"	564	368	210	621	473	175	243	110	140	70	16	52
TOS-EA-50T	TL-100	5	4"	730	520	230	718	553	245	310	160	150	70	24	80
TOS-EA-75T	TL-100	7.5	4"	730	520	230	758	593	245	310	160	150	70	24	86

Remarks: ● TOS means cast iron guide rail device. (Q.D.C:Quick Discharge Device) ● "T" means 3 phase motor.